



Content
by
Crest
Group



SCREENFLEX

Commercial Edition

Portable Room Dividers



CFSL607-DG

CFSL609-DR

CFSL6013-DS

DIVIDE AND CONQUER

Screenflex Room Dividers are the key...



◀ **Corporations**



◀ **Hospitality**

Religious & Educational Institutions

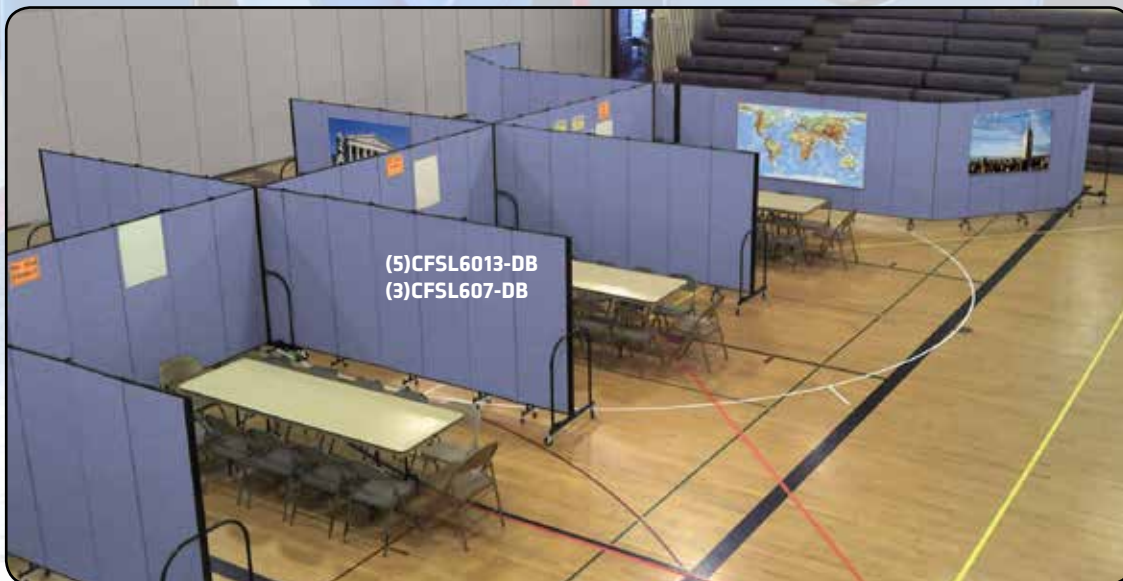

FLEXIBLE SPACE MANAGEMENT

...to many space solutions

Municipalities ▶



Industrial ▶



Libraries ▼



Healthcare ▼



INNOVATIVE EXCLUSIVE FEATURES

SOUND ABSORBING

Each panel is constructed using a 1/2" closed cell honeycomb core covered with two layers of fiberglass insulation on each side for maximum sound absorption.



TACKABLE PANELS

Tack, pin or staple items directly onto the panels.

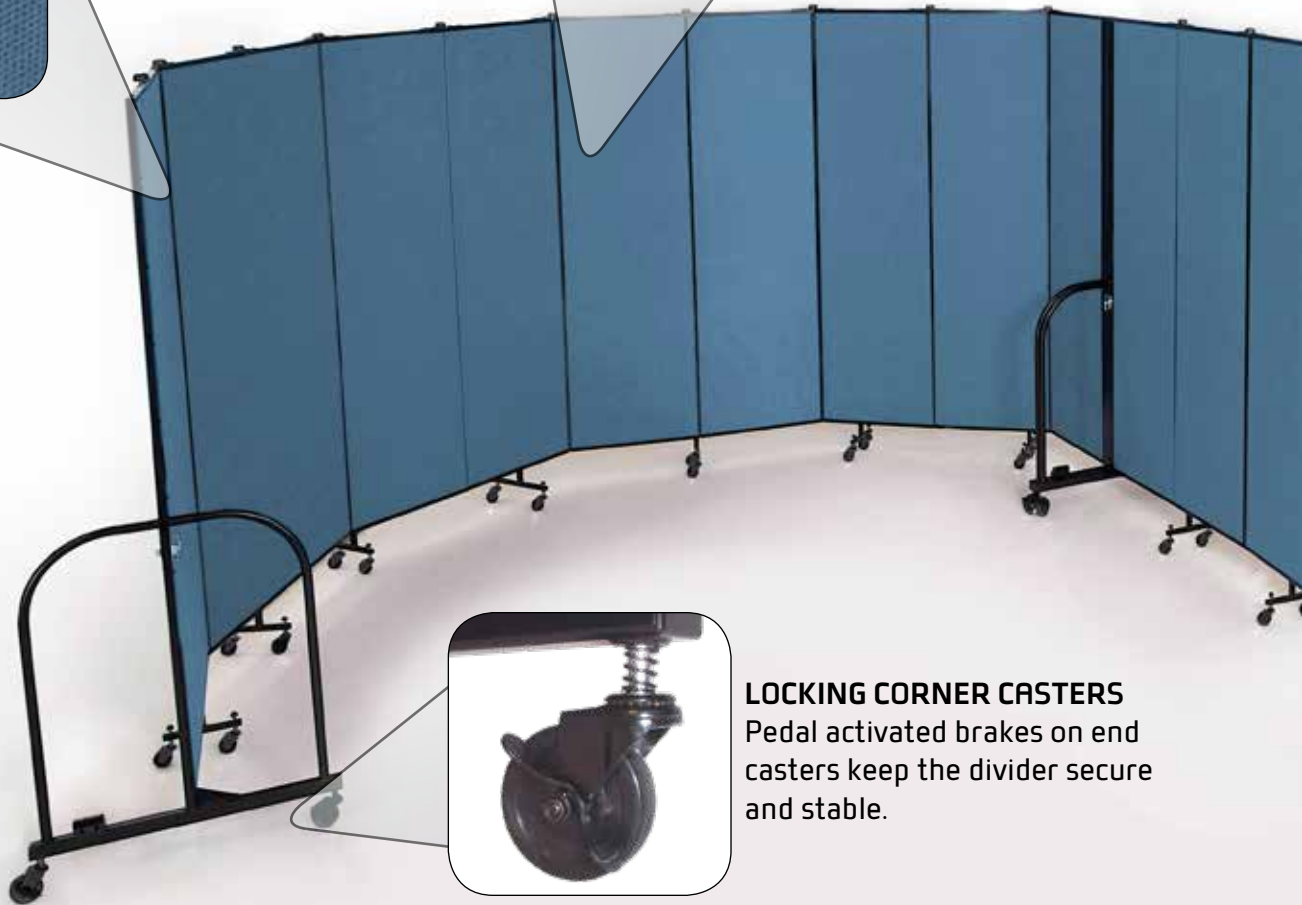

LOCKING CORNER CASTERS

Pedal activated brakes on end casters keep the divider secure and stable.



POSITION CONTROL HINGES
Molded position control hinges help the divider remain in the desired configuration.



FULL-LENGTH HINGES
A metal hinge is screwed into each panel every four inches, from top to bottom, to provide strength and stability.



(2) CFSL6011-DB

SELF-LEVELING CASTERS
Adjusting to uneven surfaces, self-leveling casters provide added stability.



STORAGE LATCHES
Locking storage latches on both ends of the divider keep the panels securely in place while moving or when closed for storage.

STANDARD/MULTI-PURPOSE



Our best-selling divider provides the flexibility to divide rooms, display material, and absorb sound. With tackable panels and exceptional stability, the Standard divider is the solution for most customer needs. The dividers arrive fully assembled and nest together for compact storage.

Screenflex Standard Dividers help solve space, time and budget problems every day in tens of thousands of facilities across the globe. Please contact your dealer for additional information on which of our 36 sizes, 17 fabric and 8 vinyl colors are best to meet your needs.



Fabrics Treated with
Scotchgard™
Fabric Protector

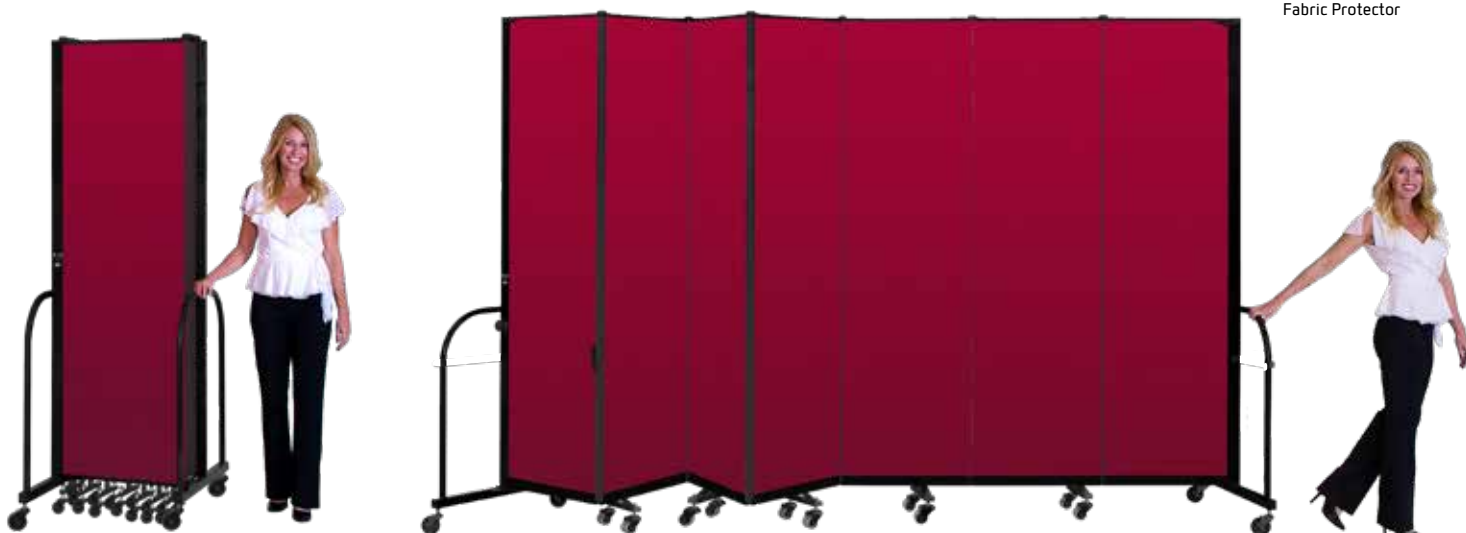

6 Heights | 6 Lengths | 17 Fabric / 8 Vinyl Colors

LENGTH	HEIGHT					
	4'-0"	5'-0"	6'-0"	6'-8"	7'-4"	8'-0"
5'-9" (3 Panel Divider)	CFSL403 72 lbs.	CFSL503 79 lbs.	CFSL603 86 lbs.	CFSL683 90 lbs.	CFSL743 99 lbs.	CFSL803 104 lbs.
9'-5" (5 Panel Divider)	CFSL405 87 lbs.	CFSL505 97 lbs.	CFSL605 107 lbs.	CFSL685 111 lbs.	CFSL745 121 lbs.	CFSL805 128 lbs.
13'-1" (7 Panel Divider)	CFSL407 102 lbs.	CFSL507 115 lbs.	CFSL607 128 lbs.	CFSL687 132 lbs.	CFSL747 143 lbs.	CFSL807 152 lbs.
16'-9" (9 Panel Divider)	CFSL409 117 lbs.	CFSL509 133 lbs.	CFSL609 149 lbs.	CFSL689 153 lbs.	CFSL749 165 lbs.	CFSL809 176 lbs.
20'-5" (11 Panel Divider)	CFSL4011 132 lbs.	CFSL5011 151 lbs.	CFSL6011 170 lbs.	CFSL6811 174 lbs.	CFSL7411 187 lbs.	CFSL8011 200 lbs.
24'-1" (13 Panel Divider)	CFSL4013 147 lbs.	CFSL5013 169 lbs.	CFSL6013 191 lbs.	CFSL6813 195 lbs.	CFSL7413 209 lbs.	CFSL8013 224 lbs.

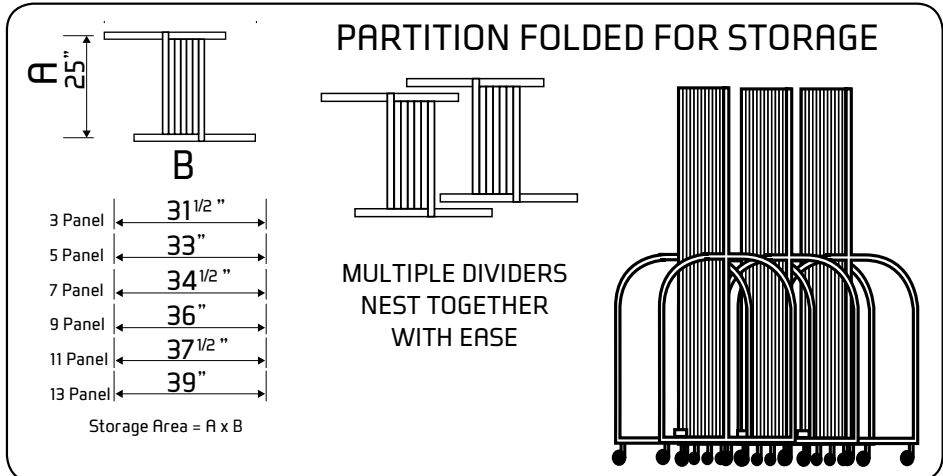
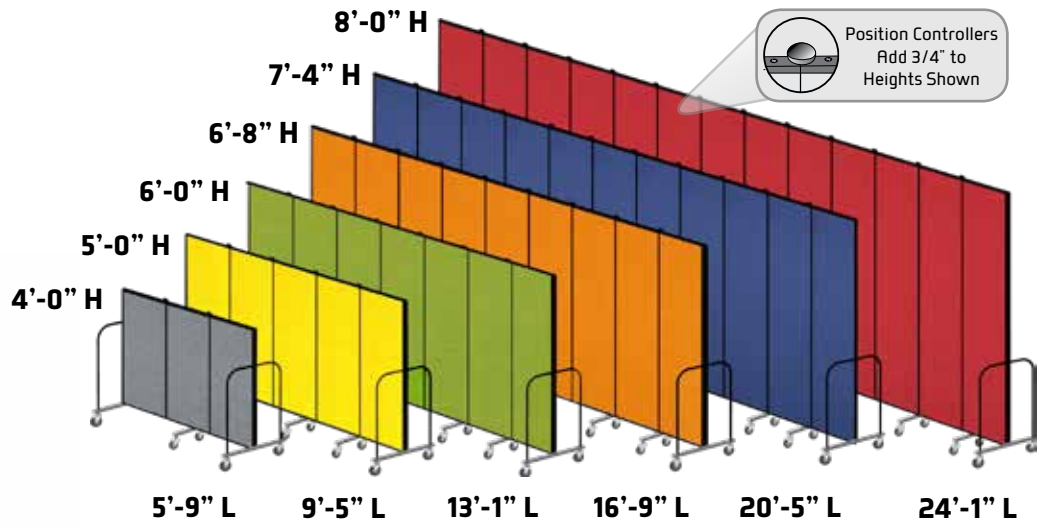

HEAVY DUTY

2 Heights | 6 Lengths | 17 Fabric / 8 Vinyl Colors

Perfect for industrial and commercial use, these dividers provide durability and functionality in hospitality, airport, arena and other rigorous environments. Extra features and more robust construction ensure flawless operation for years of use.

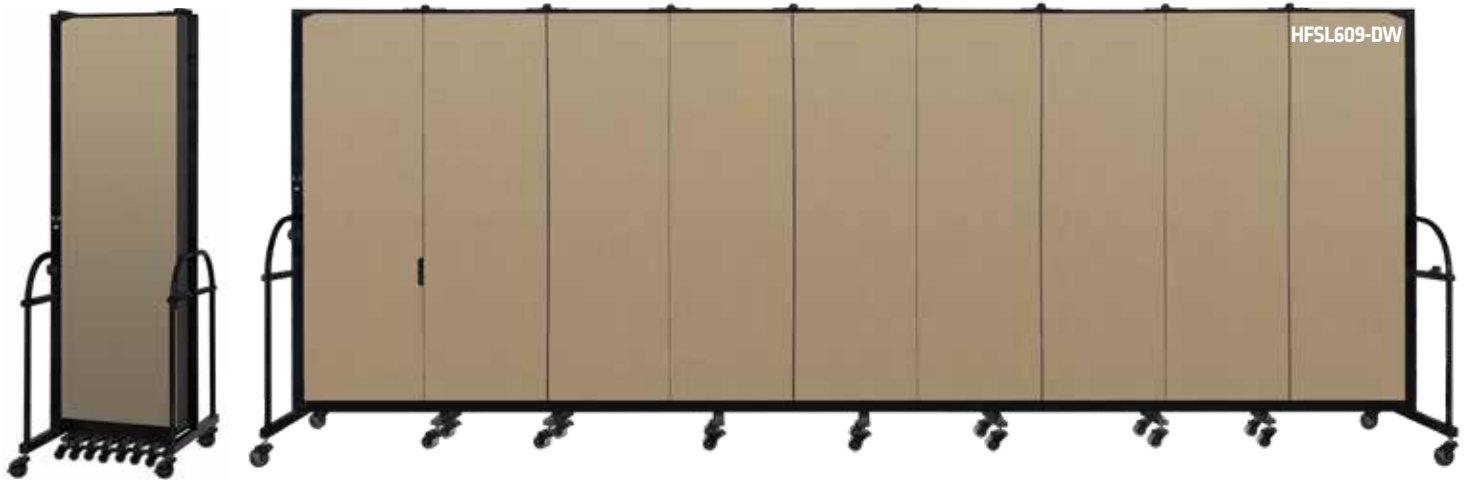

Dual Heavy Duty Casters



Upper and Lower Gusset Plates



Reinforced End Frame



Powder Painted Industrial Hinges



Strengthened Leg Assembly



Upgraded Multi-Unit Connector

LENGTH	HEIGHT	
	6'-0"	7'-4"
5'-9" (3 Panel Divider)	HFSL603 105 lbs.	HFSL743 122 lbs.
9'-5" (5 Panel Divider)	HFSL605 125 lbs.	HFSL745 144 lbs.
13'-1" (7 Panel Divider)	HFSL607 145 lbs.	HFSL747 166 lbs.
16'-9" (9 Panel Divider)	HFSL609 165 lbs.	HFSL749 188 lbs.
20'-5" (11 Panel Divider)	HFSL6011 185 lbs.	HFSL7411 210 lbs.
24'-1" (13 Panel Divider)	HFSL6013 205 lbs.	HFSL7413 232 lbs.



6 Heights | 6 Lengths | 17 Fabric / 8 Vinyl Colors

WALLmount

Divide rooms and add structure to any given space with the WALLmount divider. This divider attaches to a wall at one end and opens into the room with ease. The panels fold flat against the wall when stored.



LEFT / RIGHT ORIENTATION

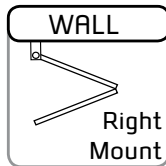
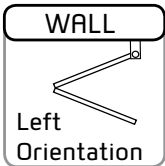

Fabrics Treated with Scotchgard™ Fabric Protector

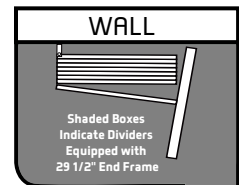
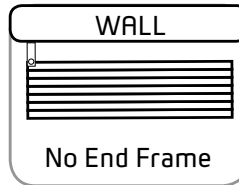

LENGTH	HEIGHT					
	4'-0"	5'-0"	6'-0"	6'-8"	7'-4"	8'-0"
5'-6" (3 Panel Divider)	CWM(L/R)403 41 lbs.	CWM(L/R)503 50 lbs.	CWM(L/R)603 54 lbs.	CWM(L/R)683 65 lbs.	CWM(L/R)743 71 lbs.	CWM(L/R)803 99 lbs.
9'-2" (5 Panel Divider)	CWM(L/R)405 55 lbs.	CWM(L/R)505 67 lbs.	CWM(L/R)605 74 lbs.	CWM(L/R)685 86 lbs.	CWM(L/R)745 93 lbs.	CWM(L/R)805 122 lbs.
12'-10" (7 Panel Divider)	CWM(L/R)407 69 lbs.	CWM(L/R)507 84 lbs.	CWM(L/R)607 94 lbs.	CWM(L/R)687 107 lbs.	CWM(L/R)747 135 lbs.	CWM(L/R)807 145 lbs.
16'-6" (9 Panel Divider)	CWM(L/R)409 83 lbs.	CWM(L/R)509 101 lbs.	CWM(L/R)609 114 lbs.	CWM(L/R)689 148 lbs.	CWM(L/R)749 157 lbs.	CWM(L/R)809 168 lbs.
20'-2" (11 Panel Divider)	CWM(L/R)4011 97 lbs.	CWM(L/R)5011 118 lbs.	CWM(L/R)6011 154 lbs.	CWM(L/R)6811 169 lbs.	CWM(L/R)7411 179 lbs.	CWM(L/R)8011 191 lbs.
23'-10" (13 Panel Divider)	CWM(L/R)4013 111 lbs.	CWM(L/R)5013 135 lbs.	CWM(L/R)6013 174 lbs.	CWM(L/R)6813 190 lbs.	CWM(L/R)7413 201 lbs.	CWM(L/R)8013 214 lbs.

LIGHT DUTY

1 Height | 2 Lengths | 17 Fabric Colors

Screenflex quality and versatility in a light weight divider. This cost effective solution is ideal for home or light duty scenarios. Divider glides effortlessly into position on ball-bearing casters.

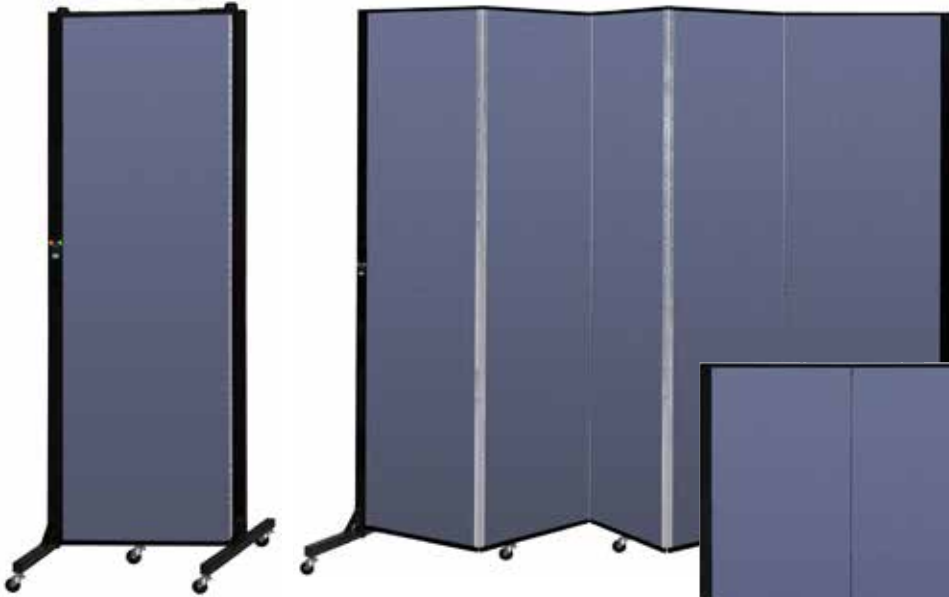

LENGTH	HEIGHT 6'-5"
5'-9" (3 Panel Divider)	BFSL683 60 lbs.
9'-5" (5 Panel Divider)	BFSL685 75 lbs.



Manually Adjustable Casters



Low Profile End Frame



3 Heights | 6 Lengths | Black Fire Barrier Fabric

FIRE RESISTANT

Screenflex Fire Resistant Screens provide the perfect solution for creating a safe welding and grinding environment. The all-steel frame plus Sandel™ Fire Barrier fabric means these Class A fire-rated dividers stand up to sparks from welding and grinding.



LENGTH	HEIGHT		
	6'-0"	6'-8"	7'-4"
5'-9" (3 Panel Divider)	CFSL603-WX 86 lbs.	CFSL683-WX 90 lbs.	CFSL743-WX 99 lbs.
9'-5" (5 Panel Divider)	CFSL605-WX 107 lbs.	CFSL685-WX 111 lbs.	CFSL745-WX 121 lbs.
13'-1" (7 Panel Divider)	CFSL607-WX 128 lbs.	CFSL687-WX 132 lbs.	CFSL747-WX 143 lbs.
16'-9" (9 Panel Divider)	CFSL609-WX 149 lbs.	CFSL689-WX 153 lbs.	CFSL749-WX 165 lbs.
20'-5" (11 Panel Divider)	CFSL6011-WX 170 lbs.	CFSL6811-WX 174 lbs.	CFSL7411-WX 187 lbs.
24'-1" (13 Panel Divider)	CFSL6013-WX 191 lbs.	CFSL6813-WX 195 lbs.	CFSL7413-WX 209 lbs.



1 Height | 2 Lengths | 17 Fabric / 8 Vinyl Colors

HEALTHFLEX

The Healthflex divider provides privacy in hospitals and other medical facilities. A factory applied antimicrobial coating protects the panels from the spread of germs.



LENGTH	HEIGHT
	5'-9"
5'-9" (3 Panel Divider)	HKDL603 35 lbs.
9'-5" (5 Panel Divider)	HKDL605 50 lbs.



DISPLAY TOWER

2 Heights | 3 or 6 Panel | 17 Fabric Colors

Tack, pin or staple artwork, flyers or other instructional material directly onto the sleek and versatile three or six-panel Display Tower. With up to 136 sq. ft. of display area, the Display Tower is a great addition to any lobby, conference room or exhibit.



Panellocks
Top and Bottom



Tackable Panels

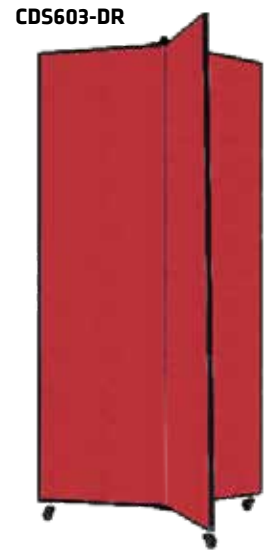

PANELS	HEIGHT		DISPLAY AREA
	5'-9"	6'-5"	
3	CDS603	CDS683	Up To 68 sq ft.
	35 lbs.	40 lbs.	
6	CDS606	CDS686	Up To 136 sq ft.
	60 lbs.	65 lbs.	

ACCOUSTICAL WALL PANEL

2 Depths | 6 Sizes | 17 Fabric Colors

Dampen the sound in any room with these sound absorbing, tackable panels. Use tacks, pins or staples to adhere items onto the panels.



Choose a Vertical or Horizontal Hanging Option

VERTICAL [x 22" W]	HEIGHT					
	42"	54"	66"	74"	82"	90"
3/4" Depth	WPS40	WPS50	WPS60	WPS68	WPS74	WPS80
1 1/2" Depth	WPD40	WPD50	WPD60	WPD68	WPD74	WPD80
HORIZONTAL [x 22" H]	LENGTH					
	42"	54"	66"	74"	82"	90"
3/4" Depth	WPSH40	WPSH50	WPSH60	WPSH68	WPSH74	WPSH80
1 1/2" Depth	WPDH40	WPDH50	WPDH60	WPDH68	WPDH74	WPDH80



DRY ERASE/TACKABLE

1 Height | 6 Lengths | Fabric Backing

Create collaborative workspaces with the perfect combination of writable surface and tackable fabric panels. Ideal for use as an instructional aide, room divider, or display board.

LENGTH	HEIGHT
	6'-0"
5'-9" (3 Panel Divider)	CFSL603WB-DX 86 lbs.
9'-5" (5 Panel Divider)	CFSL605WB-DX 107 lbs.
13'-1" (7 Panel Divider)	CFSL607WB-DX 128 lbs.
16'-9" (9 Panel Divider)	CFSL609WB-DX 149 lbs.
20'-5" (11 Panel Divider)	CFSL6011WB-DX 170 lbs.
24'-1" (13 Panel Divider)	CFSL6013WB-DX 191 lbs.



CLEAR DIVIDER

1 Height | 2 Lengths | Clear Acrylic

This movable clear acrylic divider provides **division with vision**. The 3/16" acrylic see-through panels are wet erase compatible. Use the optional Multi-Unit Connector to secure clear or fabric dividers together to create a longer wall.



LENGTH	HEIGHT
3'-4"	6'-2"
(1 Panel Divider)	CRD1 55 lbs.
10'-0"	6'-2"
(3 Panel Divider)	CRD3 120 lbs.



WHITEBOARD

1 Height | 2 Lengths | Dry Erase Surface

Whiteboard Dividers are ideal for creating collaborative spaces in schools and offices while creating privacy within your area. A white non-porous, stain resistant dry erase surface covers both sides of each divider panel to offer plenty of writable surface. The movable whiteboard is lightweight and easily rolls on self-leveling casters. Add a Multi-Unit Connector to your Whiteboard Divider to join with other Screenflex Room Dividers to create longer lengths.

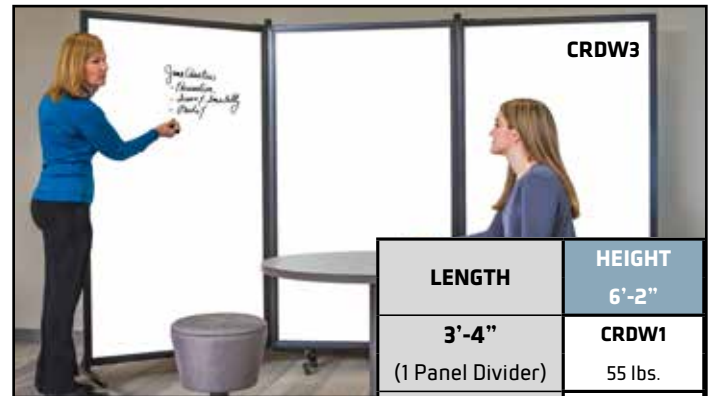

LENGTH	HEIGHT
3'-4"	6'-2"
(1 Panel Divider)	CRDW1 55 lbs.
10'-0"	6'-2"
(3 Panel Divider)	CRDW3 120 lbs.

DIVIDER OPTIONS

Multi-Unit Connector



Can Be Installed on Most Screenflex Room Dividers

Need a longer divider? Affix chrome plated latches to the end frame of most Screenflex Room Dividers to secure units together, end-to-end, for longer partitions. The connector can also be used to connect Clear Dividers.

Multi-Unit Connector
GL

One Set Per Divider
Chrome Plated

Dry Erase Panels



Convert any Screenflex panel into a wet erase panel with bright white material that can be written on and wiped clean over and over again.

HEIGHT					
3	5	7	9	11	13
DE40	DE50	DE60	DE68	DE74	DE80

Installed in Place of Fabric Panel
Installed on One Side or BOTH SIDES of Panel

DIVIDER OPTIONS

Markerboard

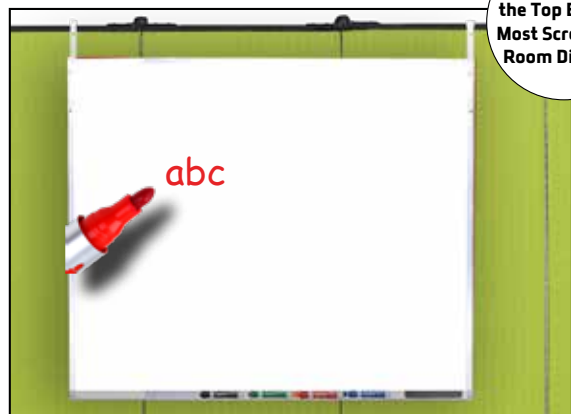

Installs Over the Top Edge of Most Screenflex Room Dividers

The optional hanging Markerboard hooks over the top of most room dividers. The included straps are adjustable for several mounting options. Surface is 1/4" thick and is dry erase compatible.

Markerboard
MBF

36" H X 42" L
Melamine Surface
Brackets Included

Windows



Factory installed windows are available in three sizes. Some restrictions apply.

WINDOW SIZE		
10" x 10"	20" x 24"	20" x 48"
WD-KIT	WD-KIT-M	WD-KIT-L

Available Sizes
10" x 10"
20" x 24"
20" x 48"

Door



Width: 24"
Multi-Unit Connector Included
25 Colors

This swing-style door opens from either direction and is held open by an industrial magnet. An optional window may be added if desired. A door panel adds 24" of length to the end of the divider.

DR40	DR50	DR60	DR68	DR74	DR80
-------------	-------------	-------------	-------------	-------------	-------------

Artwork Hanger



Can Be Used with Most Screenflex Room Dividers

Each 45" metal Artwork Hanger has eight pre-formed stamped hooks that provide light-weight support. Use to hang items or materials not suitable for pinning. Weight restrictions apply.

Artwork Hanger
AHC

8 Hooks 5" Apart

Wall Frame



Wall Frame Shown with Optional Door Panel

Once installed on a wall, this innovative option converts movable dividers and door panels into a semi-permanent installation.

Mounting Hardware Included

WALL FRAME HEIGHT			
6'-0"	6'-8"	7'-4"	8'-0"
WF60	WF68	WF74	WF80

DIVIDER OPTIONS

Applied at Factory	Please Call
Restrictions Apply	For Details



Logo/Mural Printing

Customize the look of Screenflex room dividers with a logo or full-size mural. Images can be placed onto any number of panels.



Standard Model Product Specifications

- Panels Consist of a 1/2" Closed Cell Honeycomb Core
- 3/4" Depth Sound Absorbing Tackable Panels
- Panels are Bonded with Two Layers of Fiberglass Insulation
- Each Panel is Wrapped in Vinyl or 100% Recycled Non-Woven Polyester Fabric
- #18 Gauge Metal Trim Surrounds Each Panel
- Full-Length Aluminum Hinges Join Each 22" Wide Panel Every Four Inches
- Accordion Style Construction Allows Each Panel to Fold 180 Degrees
- Position Control Hinges (top) Help Hold Panels in Place
- Non-Marking Hard Rubber Self-Leveling Casters
- Inner Legs Extend Only 3 1/2" Per Side with 2" Casters
- 29 1/2" Wide, 36" High Steel End Frame with 3" Locking Casters
- Each Height Includes a 5 1/2" Space Between the Floor and the Bottom of the Divider
- Required Space for Divider Storage is 2' x 3', with Locking Storage Latch on Each End Frame
- Manufactured Under the Protection of US Patent Number 6892784...Stabilized Portable Room Divider

Shipping Information

Shipping Point: Lake Zurich, IL 60047
Shipping Rates: Vary Based on Destination
Units Ship: Fully Assembled
Production Time: Most Orders Ship Within 5-10 Business Days

**Our Representatives Can Answer
 All of Your Shipping Questions**

Warranty Information

Lifetime Warranty: Screenflex Portable Partitions Inc. warrants its product to the original purchaser to be free from defects in workmanship and material for the life of the product. This limited warranty does not cover wear from ordinary use, improper storage or installation, abuse, neglect or damage beyond the control of Screenflex. Screenflex's obligation under this warranty shall be limited to the repair or exchange of any part which proves defective. Screenflex makes no other warranty, either expressed or implied, as to any matter whatsoever, including the product condition, its merchantability, or its fitness of any particular use or purpose. Under no circumstances shall Screenflex be liable for incidental or consequential damages. Screenflex reserves the right to modify design, specifications, and materials without prior notice. Patented Products are manufactured by Screenflex Portable Partitions Inc., Lake Zurich, IL.

DESIGNER Fabric Colors

100% RECYCLED POLYESTER



Lake (DB)



Primary Blue



Navy (DV)

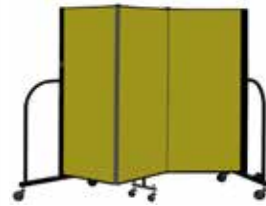

Apple Green (DA)



Mallard (DN)

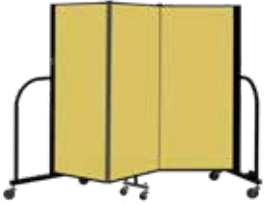

Primary Yellow (DY)



Desert (DW)



Walnut (DO)



Dark Brown (DD)

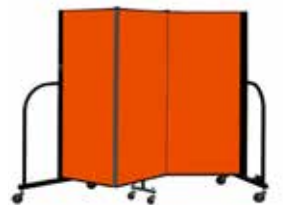

Orange (DJ)



Rose (DM)

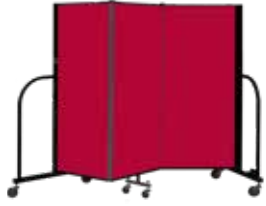

Primary Red (DR)



Auburn (DE)



Purple (DP)



White (DT)



Stone (DG)



Charcoal Black (DX)

COLOR
OPTIONS

ROYAL Vinyl Colors



Blue Tide (VB)

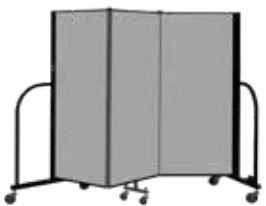

Granite (VG)



Raspberry (VM)



Mint (VN)



Sandalwood (VO)



Hazelnut (VW)



Coal (VX)

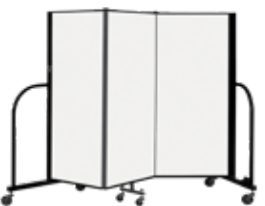

Ice (VT)

